

VP™ & UD™ Bushes



Features

Novibra® type VP™ and Metalastik® type UD™ consist of two concentric sleeves with rubber securely bonded between them. Designed to accommodate torsional movements and axial and radial loads. The rubber is prestressed to give maximum dynamic strength and durability.

The bonded rubber takes up the full movement.

Lubrication or other bearing maintenance is not required. The bush has excellent sound and vibration isolation characteristics.

Metalastik® type UD™ Bushes

Novibra® type VP™ Bushes

For vehicle suspension, pivot arms and all types of mechanical linkage, permits oscillating movement through the deflection of rubber in shear. Suitable to replace roller bearings where small motions are required (up to 20 degrees). Reduces shock loads and noise transmission in structures.

Applications:

- ▼ Pivot bearings
- ▼ Conveyor tracks
- ▼ Vibratory feeders
- ▼ Mechanical linkages
- ▼ Vehicle suspension arms

Drawing no.	Part no.	Dimensions in mm				Torsion		Axial		Radial		Weight (Kg)
		d	D	I	L	Stiffness Nm/rad	±β degrees	Stiffness N/mm	Max defl. mm	Stiffness N/mm	Max Load kN	
13-1232	10-00520	8	20	15	17	10	13	205	1,3	2000	0,7	0,02
13-1230	10-00249	10	24	15	18	14	13	180	1,7	1300	0,5	0,02
13-1782	10-00277	12,7	38,2	25,4	31,8	30	22	220	3,3	1200	1,1	0,08
13-1657	10-00271	12,7	38,2	44,5	50,8	42	22	330	3,3	2100	2,2	0,14
13-0785	10-00215	14,3	30,2	44,5	50,8	86	13	640	1,9	11000	6	0,11
13-0797	10-00218	15,9	33,4	60,3	65	140	13	960	2,1	18800	9,5	0,16
13-1004	10-00235	15,9	47,7	44,5	50,8	74	20	330	4,2	2500	2,5	0,20
13-1698	10-00276	35	71,2	41,1	45	395	14	550	5,1	3800	4,5	0,39

VP™ & UD™ Bushes

Features

Novibra® type VP™ and Metalastik® type UD™ consist of two concentric sleeves with rubber securely bonded between them. Designed to accommodate torsional movements and axial and radial loads. The rubber is prestressed to give maximum dynamic strength and durability.

The bonded rubber takes up the full movement.

Lubrication or other bearing maintenance is not required. The bush has excellent sound and vibration isolation characteristics.

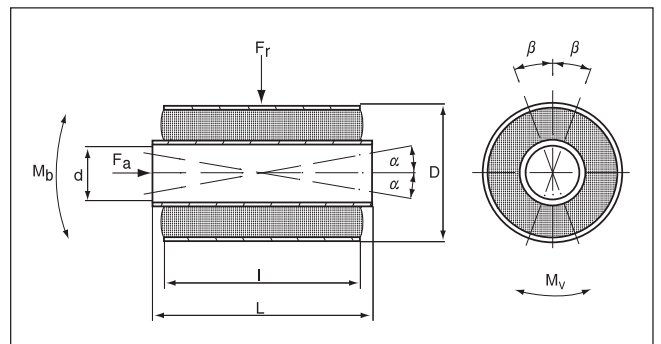

Designation Drawing no. VP Bush	Part no. 60°IRH	Dimensions in mm				Torsion			Conical		Axial Load		Radial Load		Weight (Kg)	
		d	D	L	l	Max Mv Nm/deg.	Max β deg.	Stiffness Nm/deg.	Max Mb Nm	Max α deg.	Stiffness Nm/deg.	Max Fa N	Stiffness N/mm	Max Fr N		Stiffness N/mm
10-2525	10-00021	10	25	25	20	5,0	15	0,3	6,0	8	0,7	750	170	2300	2000	0,04
10-2540	10-00022	10	25	40	35	6,0	15	0,4	38,0	8	4,8	1500	380	3800	2350	0,06
15-3530	10-00023	15	35	30	25	9,0	15	0,6	12,0	8	1,5	1500	220	3500	3000	0,08
15-3550	10-00024	15	35	50	45	15,0	15	1,0	120,0	8	15,0	2500	520	6000	6500	0,12
20-4540	10-00025	20	45	40	35	24,0	15	0,6	45,0	8	5,6	2600	330	6800	4000	0,16
20-4575	10-00026	20	45	75	70	48,0	15	3,2	365,0	8	46,0	5500	820	13500	8000	0,32
25-5045	10-00027	25	50	45	40	46,0	14	3,3	96,0	8	12,0	3800	450	9000	4500	0,21
25-5085	10-00028	25	50	85	80	49,0	14	4,9	730,0	8	92,0	7500	960	18000	10500	0,42
30-6055	10-00029	30	60	55	45	78,0	14	5,6	135,0	8	17,0	5100	530	12000	5000	0,34
35-6560	10-00031	35	65	60	50	93,0	12	7,7	180,0	6	23,0	6600	720	16000	8500	0,43
40-7065	10-00033	40	70	65	55	138,0	12	11,5	290,0	7	41,0	8300	870	20500	17000	0,56
45-7570	10-00035	45	75	70	60	240,0	12	20,0	320,0	7	45,0	10000	1100	24000	20000	0,67
50-8075	10-00037	50	80	75	65	275,0	11	25,0	700,0	7	100,0	12000	1350	28500	30000	0,77